

# AVERY DENNISON MARKETING SPECIFICATION

© 2021 AVERY DENNISON CORPORATION. ALL RIGHTS RESERVED

## HISTORY

REV	DATE	DESCRIPTION
A	9/2/2021	RELEASED

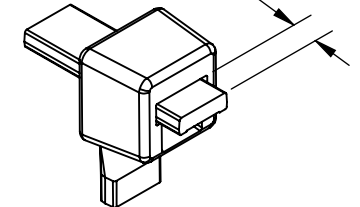
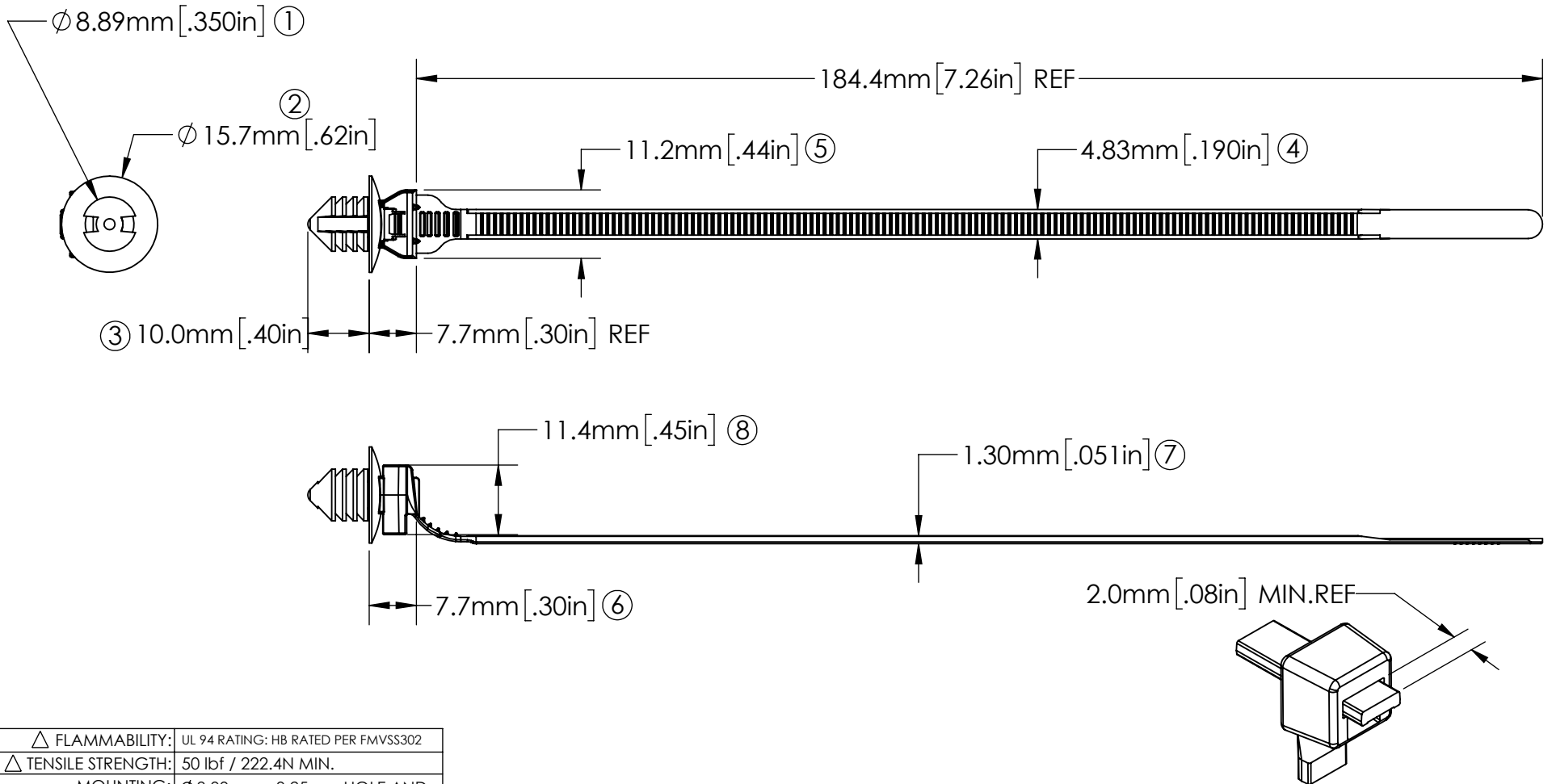

RECOMMENDED CUT LENGTH

2.0mm [.08in] MIN. REF

NOTES:  
1. SPECIAL CHARACTERISTICS ARE NOTED BY A TRIANGLE ( $\Delta$ )

APPROVALS: ENG. APPR. *Chris Strakus 09/02/21*  
Q.A. APPR. *Rick Estano 09/02/21*



FASTENER DIVISION  
FITCHBURG, MA 01420 U.S.A.  
TEL. 1-800-225-5913  
FAX. 978-353-8157

SPECIFIED TOLERANCES ARE:  
.XX  $\pm$  .03 INCHES .X  $\pm$  .7 mm  
.XXX  $\pm$  .010 INCHES .XX  $\pm$  .25 mm  
ANGULAR:  $\pm$  2°

MATERIAL  
**NYLON 6/6, IMPACT MODIFIED,  
HEAT STABILIZED, HIGH HEAT**  
COLOR  
**BROWN**

DESCRIPTION  
**CURVE TIE, 8MM, 4 FLUTE, HIGH HEAT**  
STOCK NO.  
**20094-HHBN**  
REV.  
**A**

9	$\Delta$ FLAMMABILITY:	UL 94 RATING: HB RATED PER FMVSS302
10	$\Delta$ TENSILE STRENGTH:	50 lbf / 222.4N MIN.
	MOUNTING:	$\Phi$ 8.00mm $\pm$ 0.25mm HOLE AND M10 THREADED HOLE
	INSERTION:	10lbf / 44.5N MAX
	EXTRACTION:	25lbf MIN per USCAR-44 NOM. FORCES: 40lbf / 177.9N MIN
	OPERATING TEMP RANGE:	-40°F (-40°C) TO 302°F (150°C) CONTINUOUS AND 329°F (165°C) AT MAXIMUM EXPOSURE
	WEIGHT:	1.78g
	BUNDLE DIAMETER:	$\Phi$ 1.6mm TO $\Phi$ 44.5mm
	TOOL:	12001 - HAND TOOL 12500 - PNEUMATIC TOOL
	TOOL TENSION SETTING:	6 - 8
	PACKAGING:	500/BAG, 10BAGS/MASTER

5

↑

4

3

2

1